

FRRU004-SCM4

SINGLE CONTACT MODULE

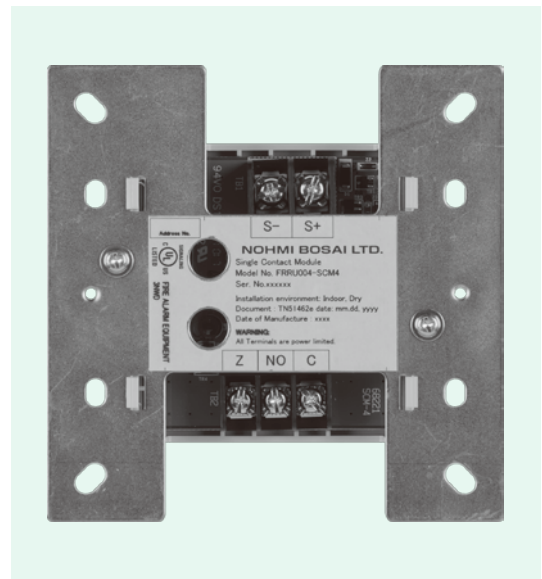

Features

- One simple LED for status indication
- NFPA Class A (Styles 6 & 7) and Class B (Style 4) for SLC
- NFPA Class B (Style B) for IDC
- Electronic address setting
- Downsized unit
- Easy installation



Description

The Single Contact Module (FRRU004-SCM4) is used to monitor the contact status of a device that contains a Normally-open contact (i.e, pull station, waterflow switch, etc). The FRRU004-SCM4 can be programmed in the panel to supervise either a normally open or Normally-closed contact on the Fire Alarm Control Panel (FACP). When the Normally-open contact is selected, and the contact is closed, the FRRU004-SCM4 reports its condition to FACP. Likewise when the Normally-closed contact is set as supervising condition, and the contact is opened, the FRRU004-SCM4 reports its condition to FACP. FRRU004-SCM4 supervises an open circuit of wiring connected to the terminal C and NO. FRRU004-SCM4 employs one red LED to indicate the status. In normal condition, the LED flashes. When the contact is activated, the LED will turn on constantly. In case of trouble, the LED will turn off.

Ordering Information

Model no. FRRU004-SCM4

Specifications

No.	Item	Specification
1	Rated voltage range of SLC input power (S+,S-)	22.0 to 24.0V
2	Maximum SLC 24 VDC standby current (S+,S-)	250μA
3	Maximum SLC 24 VDC alarm current (S+,S-)	1mA
4	IDC input circuit wiring style	Class B (Style B)
5	End-of-line resistor for IDC	5.1kΩ, 1/2W
6	Maximum wiring resistance of IDC	100Ω
7	Maximum wiring capacitance of IDC	1μF
8	Operating temperature range	0°C to 49°C (32°F to 120°F)
9	Operating humidity range	0 to 93% (non-condensing)
10	Dimensions	106mm (4.17 inches) (H) × 106mm (4.17 inches) (W) × 29mm (1.14 inch) (D)
11	Applicable electrical box for installation	North American 64mm (2-1/2 inches) deep 2-gang box Standard 4 inches square box 38mm (1-1/2 inch) deep box

Setting the Address

Each addressable module, smoke detector, heat detector and combination detector must have the address set before connecting the device to the Signaling Line Circuit (SLC) loop. The address is set using the hand held device programmer or the addressing feature on the control panel.

Installation

Figure 1: Installation into the compatible electrical box

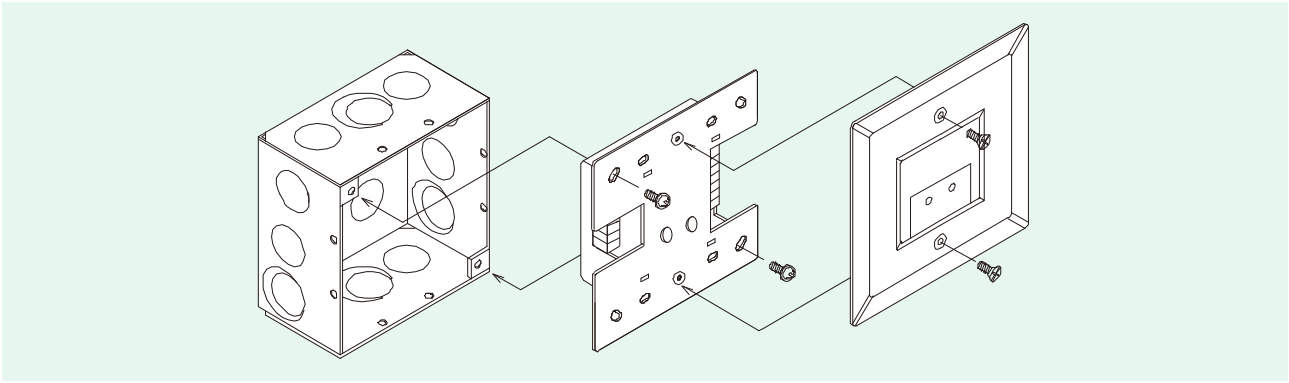

Wiring Diagram

Figure 2: Wiring diagram in case of supervising Normally-open contact

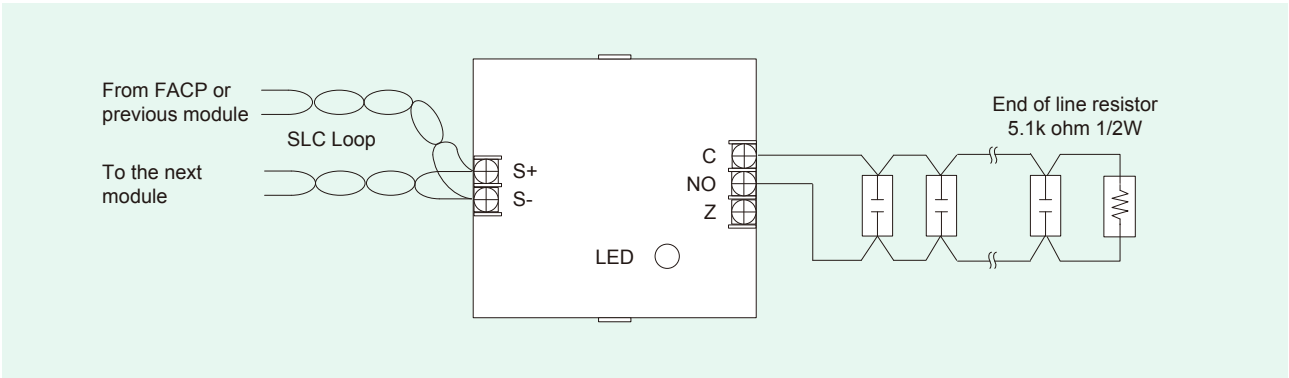
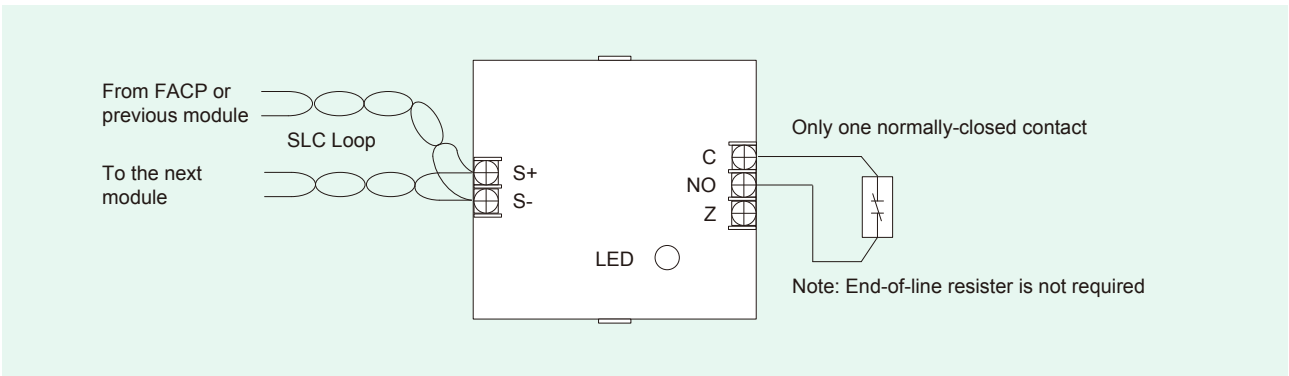

Figure 3: Wiring diagram in case of supervising Normally-closed contact (Not recognized as NFPA Initiating Device Circuit)



NOTICE

- These instructions do not purport to cover all the details or variations in the equipment described, nor provide for every possible contingency to be met in connection with installation, operation and maintenance.
- Specifications are subject to change without notice. Contact Nohmi before relying on above specifications.
- Actual performance is based on proper application of the product by a qualified professional.
- Should further information be desired or should particular problems arise, which are not covered sufficiently for the purchaser's purpose, the matter should be referred to Nohmi or a distributor in your region.

NOHMI
NOHMI BOSAI LTD.

• Head Office: 4-7-3 Kudan-Minami, Chiyoda-ku, Tokyo
102-8277, Japan
• Phone: (81)3-3265-0231
• F A X: (81)3-3265-5348
URL <http://www.nohmi.co.jp/english/>

Contact