

FRRJ001A-Y-G

ADDRESSABLE MODULE FOR GAS DETECTOR

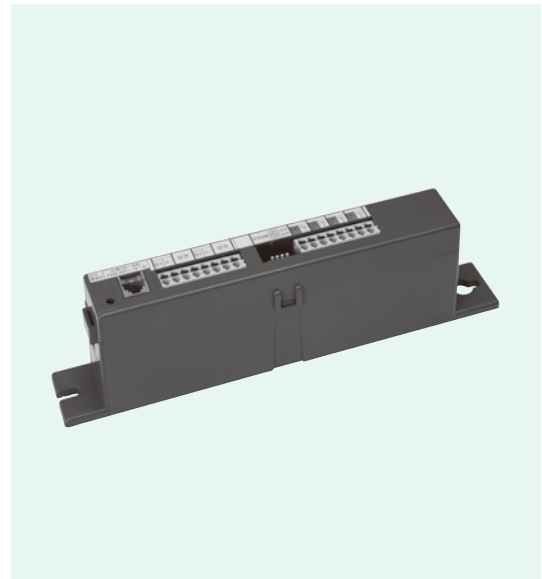

Features

- 1 address with 4 circuits
- NFPA Class A (Styles 6 & 7) and Class B (Style 4) for SLC
- Electronic address setting
- Slim unit
- Easy installation

Description

The Addressable Module for Gas Detector supervises the compatible gas detectors connected to its circuits. The FRRJ001A-Y-G has 4 circuits per unit, so that 4 different circuits can be controlled under 1 address number. The FRRJ001A-Y-G detects alarm conditions and report to the Fire Alarm Control Panel (FACP) by supervising the voltage output of connected gas detectors.

The FRRJ001A-Y-G is a slim unit, and it can be installed easily.

Ordering Information

Model no. FRRJ001A-Y-G

Specifications

No.	Item	Specification
1	Rated voltage range of SLC input power (S+,S-)	24.0V
2	Maximum SLC 24 VDC standby current (S+,S-)	250μA
3	Applicable SLC wiring style	NFPA Style 4, 6, and 7
4	No. of connectable gas detector per circuit	1 no.
5	Number of circuit per unit	4 circuits
6	Operating temperature range	-10°C to 50°C (14°F to 122°F)
7	Compatible gas detectors	Model KP35B for liquefied petroleum gas, and model KN35B for natural gas, manufactured by Fuji Electric
8	Operating relative humidity range	20 to 85% (non-condensing)
9	Dimensions	68mm (2.68 inches)(H)×232mm (9.13 inches) (W)×34mm (1.34 inches) (D)

Setting the Address

Each addressable module, smoke detector, heat detector and combination detector must have the address set before connecting the device to the Signaling Line Circuit (SLC) loop. The address is set using the hand-held device programmer or the addressing feature on the control panel.

Installation

Figure 1: Installation in an electrical enclosure

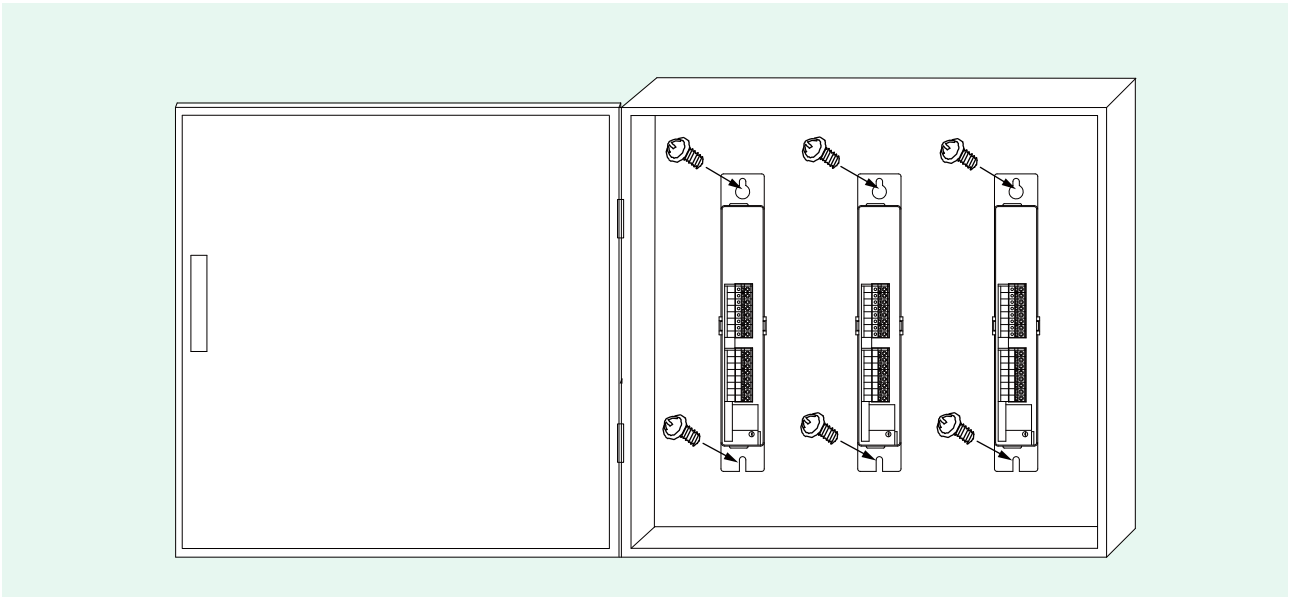

Wiring Diagram

Figure 2: Wiring diagram of FRRJ001A-Y-G

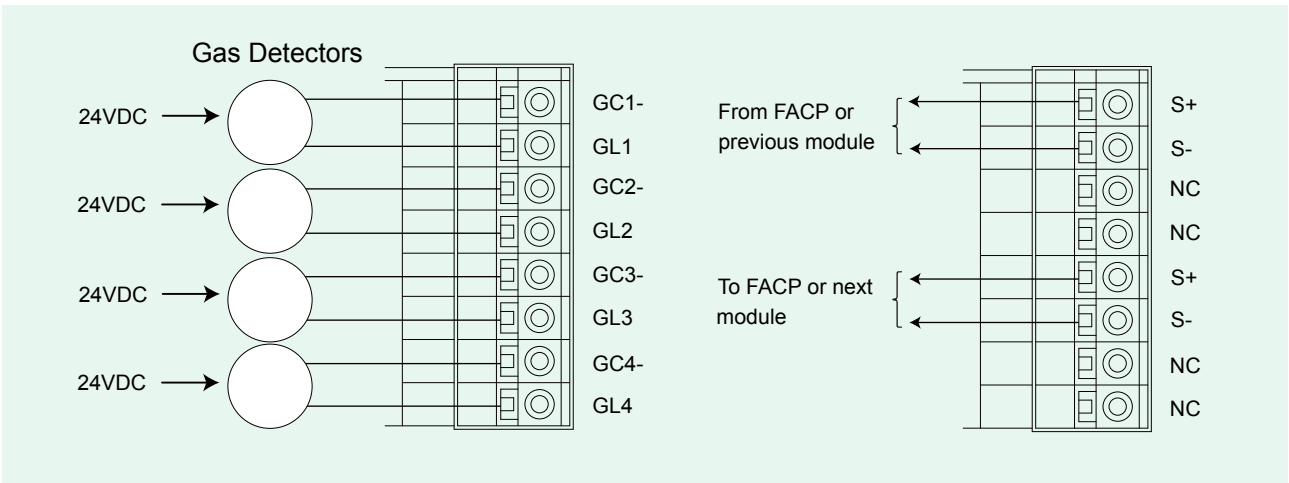

NOTE

- The information contained herein does not purport to cover all the details or variations of the equipment described, nor to provide for every possible contingency that may be met in connection with its installation, operation or maintenance.
- Specifications are subject to change without notice. Contact Nohmi before relying on the information.
- Actual performance is based on proper application of the product by a qualified professional.
- Should further information be required or should particular concerns arise that are not covered sufficiently for the purchaser's purposes, the matter should be referred to Nohmi or your nearest distributor.

NOHMI
NOHMI BOSAI LTD.

- Head Office: 4-7-3 Kudan-Minami, Chiyoda-ku, Tokyo 102-8277, Japan
 - Phone: (81)3-3265-0231
 - F A X: (81)3-3265-5348
- URL <https://www.nohmi.co.jp/english/>

Contact